



407B 1/16 DIN Multi-Mode Timer

Purchase Details:



- Selectable On-Delay/Off-Delay/Interval Timing Modes
- Separate Start Input
- Output Contacts rated 10A at 120/240 VAC and 30 VDC
- Six Timing Ranges in a single unit:
1 and 10 sec., min., and hours
5 and 50 sec., min., and hours
- Universal Power Supply; 24-240 VAC and 24 VDC
- 48mm² DIN Standard housing
- Large and easy to read dial shows decimal points
- Round (octal) socket mount or mount in panel cutout
- Watertight when panel mounted
- Range and Mode select are tamper proof when panel mounted
- Unique flashing cycle progress indication

Product Contact:

Sales Contact Technical Contact

Specifications:

Models	407B100F3X 407B500F3X	On Delay, Off Delay, Interval Timing with (1) DPDT relay (1 or 10 SEC/MIN/ HRS) On Delay, Off Delay, Interval Timing with (1) DPDT relay (5 or 50 SEC/MIN/ HRS)
Contact Rating		Both models available in 6 ranges from 1 sec. to 10 hrs. or 5 sec. to 50 hrs. Rated 10 AMPS resistive at 30 VDC or 250 VAC (or less) 1/8 HP @120 VAC 1/4 HP @ 240 VAC, 240 VA @ 240 VAC LIFE: 10 million operation with no load 100,000 operations with: 10 AMPS at 30 VDC (or less) or 10 AMPS at 250 VAC (or less)
Contact Material		Silver Cadmium Oxide
Temperature Rating		0 to 122°F (-18° to 50°C)
Noise Immunity		Showering ARC per NEMA ICS 2-230 In addition, the 407B will withstand a voltage surge of 4500 volts for 50 µsec. without damage.
Mounting		Plug-in 11-Pin round base Options: Surface mounting socket DIN rail mounting socket Panel-mounting adapter kit Plug-on socket kit
Power Requirements		Universal power supply - reverse polarity protected Unit will accept power from 24 to 240 VAC, 50 or 60 Hz, (+10%, -20%) 24 VDC (+20%, -20%) Inrush - 1.5 Amps Power required - 1.2 watts

Downloadable Files:

407B Series



Product Detail:

Multiple Timing Modes: The 407B is available with selectable On-Delay, Off-Delay or Interval timing modes. These timing modes energize a set of DPDT output contacts. When in the On-Delay mode, the 407B begins timing when the timer is energized. In On-Delay mode, the contacts transfer at time out. When in the Off-Delay mode, the 407B begins timing when the Start input is de-energized. In Off-Delay mode, the contacts transfer at time out. When in the Interval mode, the contacts transfer when the timer is energized. In Interval mode, the contacts release at time out.

Universal Power Supply: All 407B timers can be powered using 24-240 VAC or 24 VDC power, greatly simplifying ordering and inventory management of replacement units.

High Accuracy: The 407B's timing circuit is not a simple RC circuit. It utilizes the sophistication of a proprietary integrated circuit that includes counting technology along with a stable oscillator to provide repeatable time delays.

1/16 DIN Housing: The 48mm² (1/16 DIN) housing is compact and is watertight when panel mounted. The 407B is mounted in an 11-pin round socket. With an optional mounting clip, the 407B can be panel mounted. The Dial on the 407B is extra large and is easy to read. When fractional ranges are selected, decimal points are clearly indicated.

The Mode select and Range select switches are located on the side of the unit, so that when panel mounted, these switches are not accessible to the operator. This tamper proof feature prevents unauthorized or hazardous changes to the timing mode and range from being made.

Cycle Progress Indication: The 407B LED indicator provides a unique and effective method of cycle progress indication. Off before timing, the LED blinks at an ever increasing rate as the cycle progresses; once every 3-1/2 seconds during the first 10% of the cycle, twice during the second 10%, and so on. At time out, the LED pulses at a high rate. (In the 1, 5, 10 and 50 second ranges, the LED is Off before timing, steady On during timing, and pulsing On after time-out).

Part Numbers:

Create Model Number >>>>>	407B			3	
Range					
Six dial-selected ranges (1 or 10 Sec/Min/Hrs)	100				
Six dial-selected ranges (5 or 50 Sec/Min/Hrs)	500				
Voltage & Frequency					
24 to 240 VAC (50/60 Hz) and 24 VDC		F			
24 VDC (low inrush current for short-circuit protected sensors)		N			
Arrangements					
11-pin On-Delay, Off-Delay, Interval Timing Modes			3		
Features					
Standard					X
Special					K

Options:

Accessories	
11-Pin surface/DIN rail socket	0000-825-86-00
Hold down for above socket	0405-025-07-00
Panel mounting bracket	0405-320-02-00
Plug-in socket kit (11-pin)	0314-260-07-00
11-Pin panel socket w/rear facing terminals	600-3-0012

		Maximum ripple @ 100Hz - 5% Current required - 50mA Power required - 1.2 watts "F" option - Peak inrush current = 2 AMPS @ 24 VDC "N" option - Peak inrush current = 150 mA @ 24 VDC
	DC	Varies as a function of temperature. Any voltage (constant temperature): $\pm 0.5\%^*$ Any voltage (32° F to 140° F): $\pm 1.5\%^*$ Any voltage (0° F to 140° F): $\pm 2.0\%^*$ *Variation from average actual time.
Repeat Accuracy		2% of range, with the exception of 50 mSec on the 1 second range
Minimum Setting		$\pm 5\%$ of range
Setting Accuracy		
	a	0 to 20 mSec power interruption: guaranteed no reset.
	b	20 to 65 mSec; it may reset (40 mSec typical reset).
Reset	c	Over 65 mSec guaranteed to reset.
		The TDR will reset properly and not start timing when subjected to an open start switch leakage of 1.5 mA or less. (Prox switch & Triac drive applications)
Terminal #6 (Start switch requirements- Off-Delay)	DC	Minimum Current Rating - 50mA Maximum saturated voltage drop -
	AC	Minimum Current Rating - 1.5 A
Weight		5 oz. (140g)

Multiple Timing Modes: The 407B is available with selectable ON-Delay, OFF-Delay or Interval timing modes. These timing modes energize a set of DPDT output contacts. When in the ON-Delay mode, the 407B begins timing when the timer is energized. In ON-Delay mode, the contacts transfer at time out. When in the OFF-Delay mode, the 407B begins timing when the Start input is de-energized. In OFF-Delay mode, the contacts transfer at time out. When in the Interval mode, the contacts transfer when the timer is energized. In Interval mode, the contacts release at time out.

Universal Power Supply: All 407B timers can be powered using 24-240 VAC or 24 VDC power, greatly simplifying ordering and inventory management of replacement units.

High Accuracy: The 407B's timing circuit is not a simple RC circuit. It utilizes the sophistication of a proprietary integrated circuit that includes counting technology along with a stable oscillator to provide repeatable time delays.

1/16 DIN Housing: The 48mm² (1/16 DIN) housing is compact and is watertight when panel mounted. The 407B is mounted in an 11-pin round socket. With an optional mounting clip, the 407B can be panel mounted.

The Dial on the 407B is extra large and is easy to read. When fractional ranges are selected, decimal points are clearly indicated.

The Mode select and Range select switches are located on the side of the unit, so that when panel mounted, these switches are not accessible to the operator. This tamper proof feature prevents unauthorized or hazardous changes to the timing mode and range from being made.

Cycle Progress Indication: The 407B LED indicator provides a unique and effective method of cycle progress indication. Off before timing, the LED blinks at an ever increasing rate as the cycle progresses; once every 3-1/2 seconds during the first 10% of the cycle, twice during the second 10%, and so on. At time out, the LED pulses at a high rate. (In the 1, 5, 10 and 50 second ranges, the LED is OFF before timing, steady ON during timing, and pulsing ON after time-out).

OPERATION

Timing begins when the start switch is closed (ON-delay and INT modes) or opened (OFF-delay mode). This starts an oscillator which runs at a frequency determined by the time setting. A fixed number of counts from the oscillator determines the end of the timing cycle. The time required to accomplish this depends upon the oscillator frequency. During timing, An LED located on the dial face blinks. For the first 10% of the cycle, the LED repeatedly blinks once followed by a pause. For the second 10%, it blinks twice and so on indicating the cycle progress. The LED flashes rapidly and continuously after time out.

ON-DELAY MODE: At time out, the DPDT relay transfers its contacts. These contacts remain transferred until the start switch is opened or power is removed by some other means.

INTERVAL MODE: When the start switch is closed, the DPDT relay transfers its contacts. The contacts remain transferred until time out. The timer will not start again until the start switch is opened or power is removed by some other means. The 407B then resets and is ready for another cycle.

OFF-DELAY MODE: Power must be applied to the timer before and during timing (terminals #10 & 2). Upon closure of the start switch, the DPDT relay transfers its contacts. The timing begins when the start switch is opened. The relay remains energized during timing. At time out, the relay de-energizes.



1/16 DIN Multi-Mode Timer

- Selectable ON-Delay/OFF-Delay/Interval Timing Modes
- Separate Start Input
- Output Contacts rated 10A at 120/240 VAC and 30 VDC
- Six Timing Ranges in a single unit
- 1 and 10 SEC, MIN, and hours
5 and 50 SEC, MIN, and hours
- Universal Power Supply; 24-240 VAC and 24 VDC
- 48mm² DIN Standard housing
- Large and easy to read dial shows decimal points
- Round (octal) socket mount or mount in panel cutout
- Watertight when panel mounted
- Range and Mode select are tamper proof when panel mounted
- Unique flashing cycle progress indication

The 407B Directly Replaces 407A.

Special note for Off-Delay operation: When operated from AC, the start switch must be of a dry contact type such as a relay contact or mechanical switch. When operated from DC, the start switch can be a dry contact type such as a relay contact or mechanical switch. In addition, a solid-state device may be used as long as its saturation voltage drop is less than 1.5 VDC at 50mA.

1/16 DIN Timers // 407B Series

SPECIFICATIONS		
MODELS	407B100F3X	ON-Delay, OFF-Delay, Interval Timing with (1) DPDT relay (1 or 10 SEC/MIN/HRS)
	407B500F3X	ON-Delay, OFF-Delay, Interval Timing with (1) DPDT relay (5 or 50 SEC/MIN/HRS)
Both models available in 6 ranges from 1 SEC to 10 HRS or 5 SEC to 50 HRS		
CONTACT RATING	Rated 10 AMPS resistive at 30 VDC or 250 VAC (or less) 1/8 HP @120 VAC 1/4 HP @ 240 VAC, 240 VA @ 240 VAC	
	LIFE: 10 million operation with no load 100,000 operations with: 10 AMPS at 30 VDC (or less) or 10 AMPS at 250 VAC (or less)	
CONTACT MATERIAL	Silver Cadmium Oxide	
TEMPERATURE RATING	0°F-122°F (-18°C to 50°C)	
NOISE IMMUNITY	Showering ARC per NEMA ICS 2-230 In addition, the 407B will withstand a voltage surge of 4500 volts for 50 µsec. without damage.	
MOUNTING	Plug-in 11-Pin round base	
	Options: Surface mounting socket DIN rail mounting socket Panel-mounting adapter kit Plug-on socket kit	
POWER REQUIREMENTS	Universal power supply - reverse polarity protected Unit will accept power from 24 to 240 VAC, 50 or 60 Hz, (+10%, -20%) 24 VDC (+20%, -20%)	
	AC	Inrush - 1.5 Amps Power required - 1.2 watts
	DC	Maximum ripple @ 100Hz - 5% Current required - 50mA Power required - 1.2 watts "F" option - Peak inrush current = 2 AMPS @ 24 VDC "N" option - Peak inrush current = 150 mA @ 24 VDC
REPEAT ACCURACY	Varies as a function of temperature. Any voltage (constant temperature): ±0.5%*	
	Any voltage (32° F to 140° F): ±1.5%*	
	Any voltage (0° F to 140° F): ±2.0%*	
*Variation from average actual time.		
MINIMUM SETTING	2% of range, with the exception of 50 mSEC on the 1 second range	
SETTING ACCURACY	±5% of range	
RESET	a	0 to 20 mSEC power interruption: guaranteed no reset.
	b	20 to 65 mSEC; it may reset (40 mSEC typical reset).
	c	Over 65 mSEC guaranteed to reset.
The TDR will reset properly and not start timing when subjected to an open start switch leakage of 1.5 mA or less. (Prox switch & Triac drive applications)		
TERMINAL #6 (Start switch requirements-Off-Delay)	DC	Minimum Current Rating - 50mA Maximum saturated voltage drop - 1.5 VDC
	AC	Minimum Current Rating - 1.5 A
WEIGHT	5 oz. (140g)	

MODEL NUMBER >>>>>>	407B		3
Range			
Six dial-selected ranges (1 or 10 SEC/MIN/HRS)		100	
Six dial-selected ranges (5 or 50 SEC/MIN/HRS)		500	
Voltage & Frequency			
24 to 240 VAC (50/60 Hz) and 24 VDC		F	
24 VDC (low inrush current for short-circuit protected sensors)		N	
Arrangement			
11-pin ON-Delay, OFF-Delay, Interval Timing Modes			3
Features			
		Standard	X
		Special	K
Accessories			
11-Pin surface/DIN rail socket	0000-825-86-00		
Hold down for above socket	0405-025-07-00		
Panel mounting bracket	0405-320-02-00		
11 Pin panel socket w/rear facing terminals	600-3-0012		
Plug-in socket kit (11-pin)	0314-260-07-00		

WIRING

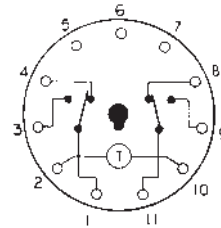
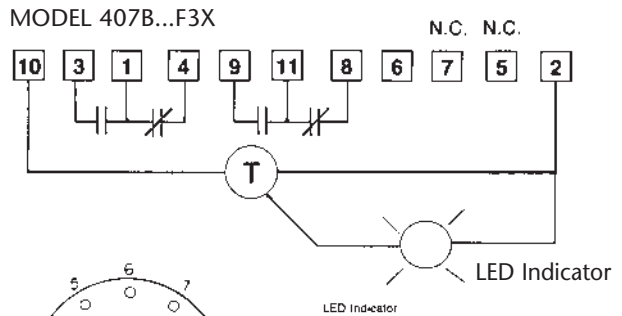

TERMINAL WIRING CAUTION! Do NOT connect terminal 6 to L1 (AC Hot or DC+). Damage to unit will result. Terminal 6 is a dry contact only!

DIMENSIONS (INCHES/MILLIMETERS)

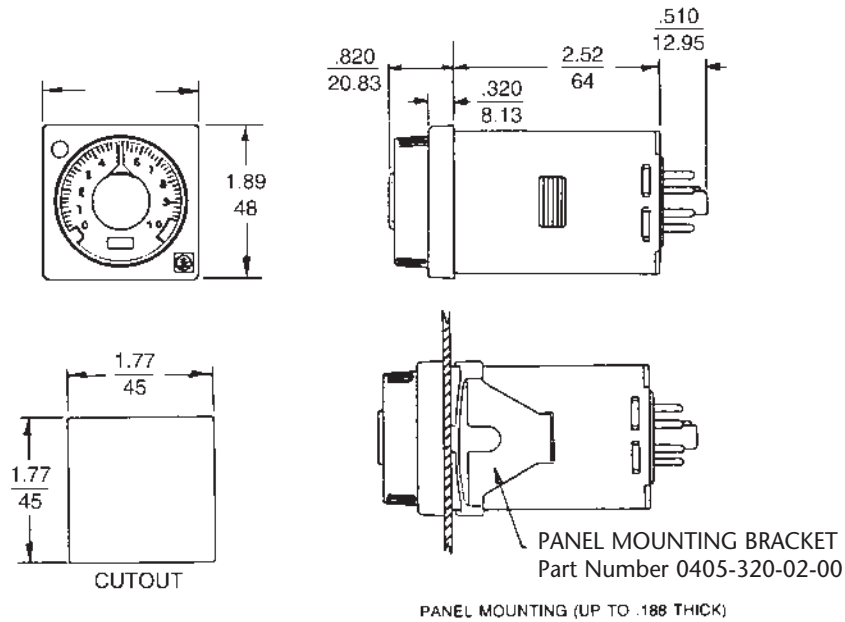

Optional 11-Pin Socket
Part Number 0000-825-86-00

TYPICAL CIRCUITS

ON-DELAY (Mode Switch in ON-DELAY POSITION)

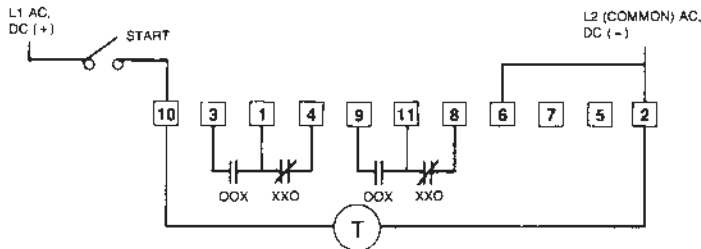

OFF-DELAY (Mode Switch in OFF-DELAY POSITION)

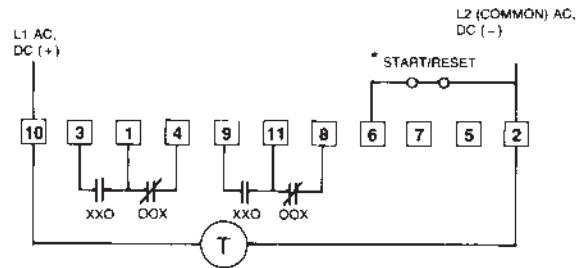

INTERVAL (Mode Switch in INTERVAL POSITION)

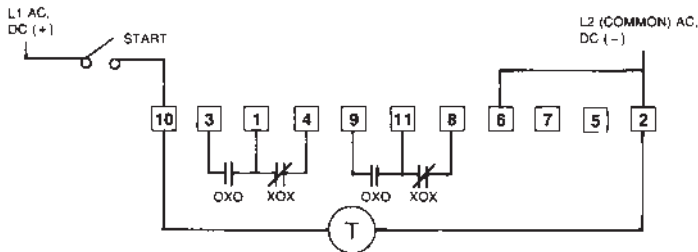

*in off-delay mode, start switch must be isolated.

Do NOT connect any load in parallel

